

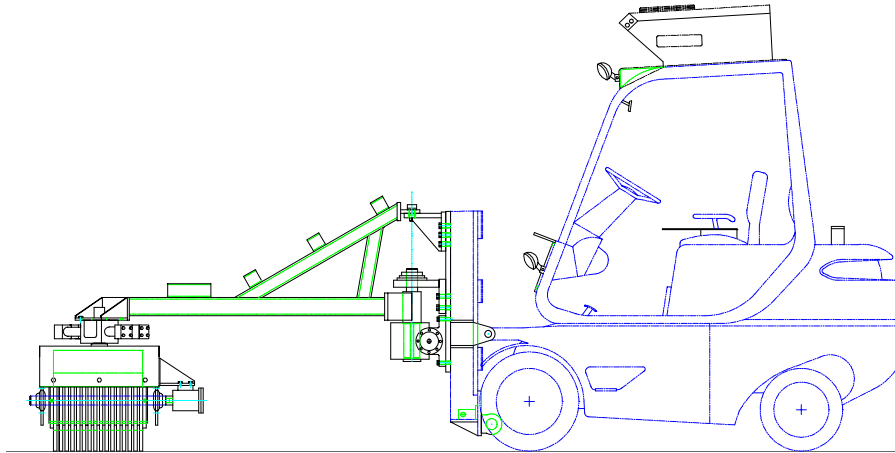

Goldendale Aluminum DECK TRIMMING MACHINE



Developed at Goldendale Aluminum as an alternative to **expensive**, completely **custom** built, mobile deck trimming(sweeping) machines.

- | | |
|---|--|
| <ul style="list-style-type: none">• Durable - Mounted on Linde Vehicle with smooth hydrostatic transmission.• Ergonomic –Joystick Control with armrest to reduce fatigue.• Safe – Eliminates the strains, sprains and burns associated with manual sweeping of cathode deck plates.
Operator is protected from splashes and heat stress by the enclosed, air-conditioned cab.• Fast – Performs sweeping while progressing continuously along the cell.• Labor Saving – Performs the sweeping operation in seconds, instead of minutes. | <ul style="list-style-type: none">• Smart – Computer controller monitors brushing pressure and automatically varies height of the mechanism to follow the contour of the deck plate and maintain consistent brushing action.• Modular – Electrical controls consist of just one enclosure and connection cables. One hydraulic function stack contains all hydraulic valves.• Operator Interface Screen Notifies operator of planned maintenance, contains operating instructions, and aids troubleshooting. (optional) |
|---|--|

Goldendale Aluminum email: markcase@goldendalealu.com
85 John Day Dam Road Goldendale, WA 98620
Phone: (509) 773-7305 Fax: (509) 773-7276